

DYNAPRO 6 FRONT BRAKE KIT FOR FIAT 500 2012-PRESENT

Models Covered:

- Fiat 500 2012 - Present

Kit Features:

- Performance upgrade from 4-piston calipers for aggressive street / track vehicles and dedicated competition machines.
- Simple bolt-on installation with no modifications required.
- Fully compatible with ABS and OE master cylinder output.

Component Features:

DynaPro 6 Billet Lug Mount Calipers

- Performance advantages of a larger pad compared to four piston calipers.
- Differential bore six piston design generates big brake clamping force with balanced pad loading for even wear in all sustained high heat, high load conditions.
- DynaPro 6 calipers use stainless pistons to resist corrosion and reduce heat transfer from the pads.
- Exclusive Quick-E brake pad retention clips for simplified pad service without caliper removal.
- High temperature, fluid resistant high gloss black finish is standard, with red and other Wilwood colors available.

SRP or ULHP Series 12.19" Diameter Rotors

- Directional vane rotors provide the highest degree of cooling efficiency with increased surface area and improved air circulation between the rotor faces.
- ULHP rotors provide high performance and rugged durability for a wide range of competition, performance, and sport driving applications. Rotors are cast from premium grade, long grain carbon iron.
- SRP series rotors feature the high performance and high-tech styling of our signature directional drill and slot pattern and durable black E-coat finish that keeps them looking good mile after mile.

Forged Aluminum GT Mounting Hats

- Forged aluminum rotor mount hats help reduce weight with the strength to handle the exceptional brake torque delivered by the DynaPro 6 caliper.
- Black anodized finish resists corrosion while adding to the aggressive competition look inside the wheel.

Wilwood BP-10 "Smart Pads"

- All kits include BP-10 metallic-composite compound "Smart Pads". BP-10 delivers the increased friction; higher fade resistance, and longer wear of an entry-level track pad, with virtually noise and dust free performance for the street.
- Optional race-only compounds can be ordered to suit the braking requirements at all levels of severe duty and sustained high heat competition.

Hardware and Plumbing

- Installation is simple. The kit is a complete bolt-on without the need to modify any of the existing brake or suspension components. Aluminum mounting brackets and premium grade hardware are supplied with detailed installation instructions in every kit.
- Stainless steel braided competition flex line kits, with machine crimped ends and the fittings necessary to connect the calipers with the OE chassis bulkhead are included with the kit.



Front Kit with SRP Rotor and Red Caliper
Download high resolution photo,
[click here](#)

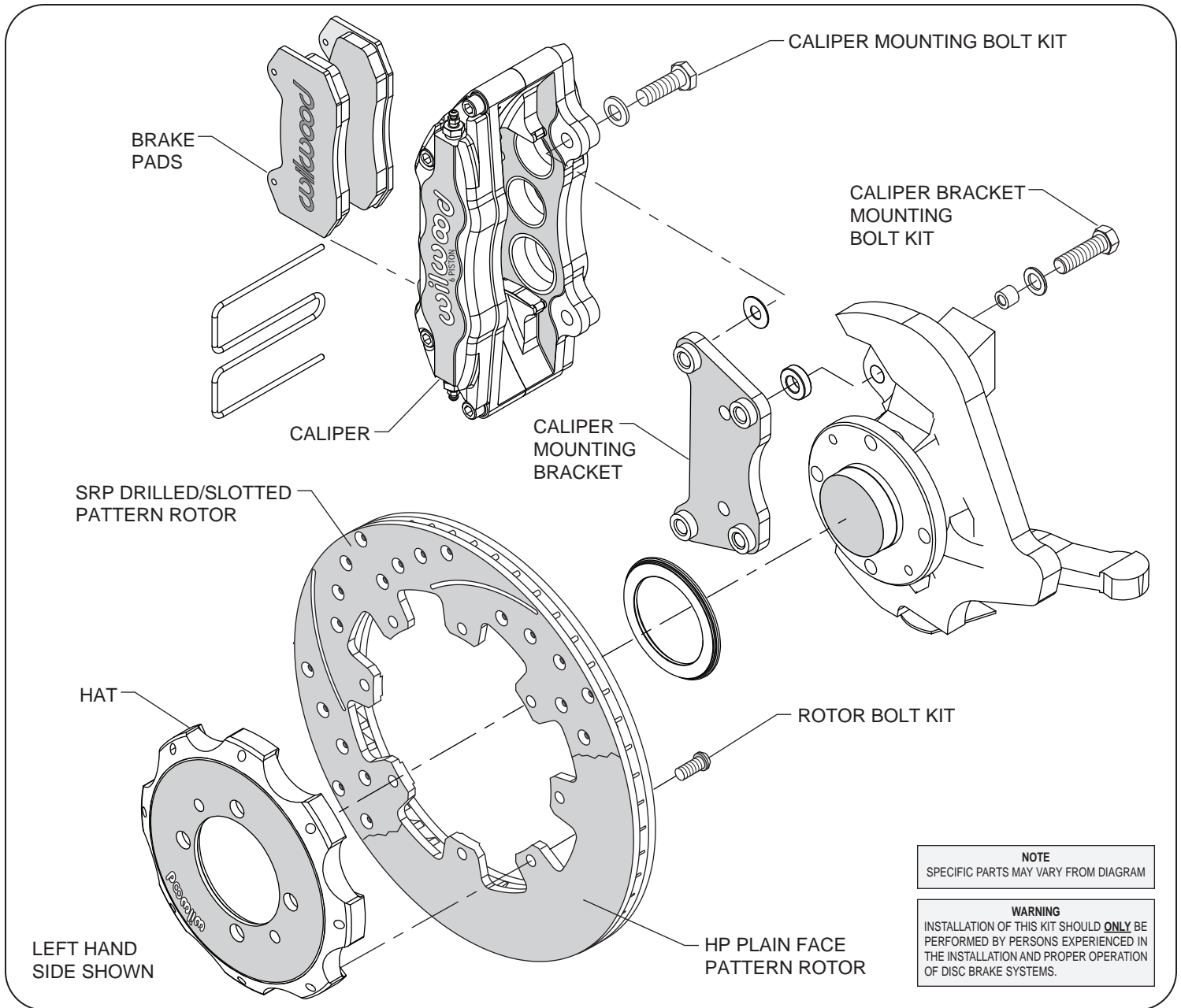

Typical Installation Diagram

ORDERING INFORMATION:

PART NUMBER	DESCRIPTION
140-12767	Front Kit, Fiat 500, DynaPro 6 Caliper, 12.19" ULHP Rotor
140-12767-D	Front Kit, Fiat 500, DynaPro 6 Caliper, 12.19" SRP Drilled and Slotted Rotor
140-12767-DR	Front Kit, Fiat 500, DynaPro 6 Caliper, 12.19" SRP Drilled & Slotted Rotor, Red Caliper
140-12767-R	Front Kit, Fiat 500, DynaPro 6 Caliper, 12.19" ULHP Rotor, Red Caliper



Need additional information - fast? Utilizing your Smartphone, scan the image at the left to jump to our web site. This code takes you to our home page and social media sites where information is just a click away, [or click here.](#)

COMBINATION PARKING BRAKE REAR KIT FOR 2012-PRESENT FIAT 500

Models Covered:

- Fiat 500 2012 - Present

Kit Features:

- Combination hydraulic-mechanical parking brake calipers use hydraulic pressure for stopping and a mechanical lock for parking.
- 11.00" rotor provides improved stopping power, balanced rear bias, and competitive styling to compliment front brake upgrades in conjunction with wheel, tire, and suspension modifications.
- Caliper brackets and installation hardware are engineered specific to the Fiat 500.

Component Features:

Combination Hydra-Mechanical Parking Brake Caliper

- Single piston floating mount calipers are securely attached to the axle with a fixed radial mount bracket on the axle.
- The floating mount caliper maintains perfect alignment when the cable actuated mechanical parking brake lock is engaged and then released.
- Correct alignment is maintained over the disc as the pads wear and pad knock back is minimized.
- Radial mounting provides secure attachment to the axle housing end and precise adjustments for pad to rotor alignment.
- The cable actuated parking brake is easily adapted to the original cable system on most vehicles. Cables for aftermarket hand brake lever kits are easily configured for custom fabricated installations.

SRP and ULHP Series Rotors

- Directional vane rotors provide the highest degree of cooling efficiency with increased surface area and improved air circulation between the rotor faces.
- SRP rotors feature an engineered directional drill and slot pattern for an aggressive high-tech look inside the wheel. The holes and slots enhance pad performance by reducing glaze and dispersing the gasses and some of the heat generated during braking.
- ULHP rotors are precision machined, smooth face discs. The additional mass of the non-drilled HP disc adds service life and improved cooling on competition or other vehicles subjected to sustained high operating temperatures.

GT Forged Aluminum Rotor Hats

- Premium grade alloy forged aluminum hats are light to reduce rotating weight and strong to provide secure mounting of the disc over the OE axle flange.
- The high luster black anodized finish resists corrosion and enhances the custom appearance inside the wheel.

Wilwood BP-10 "Smart Pads"

- BP-10 metallic-composite compound "Smart Pads" deliver the increased friction, higher fade resistance, and longer wear of an entry level track pad, with virtually noise and dust-free operation for the street.

Mounting Hardware and Plumbing

- Caliper mounts are engineered for precise fit and secure installation. Premium grade fasteners and alignment shims are included for a professional installation.
- Stainless steel braided flexline kits with machine crimped ends include the fittings necessary to connect the calipers to the OE brake line fitting at the chassis and are included with the kit.



Combination Caliper Rear
Parking Brake Kit with SRP Rotor
Down Load High Resolution Photo,
[click here](#)

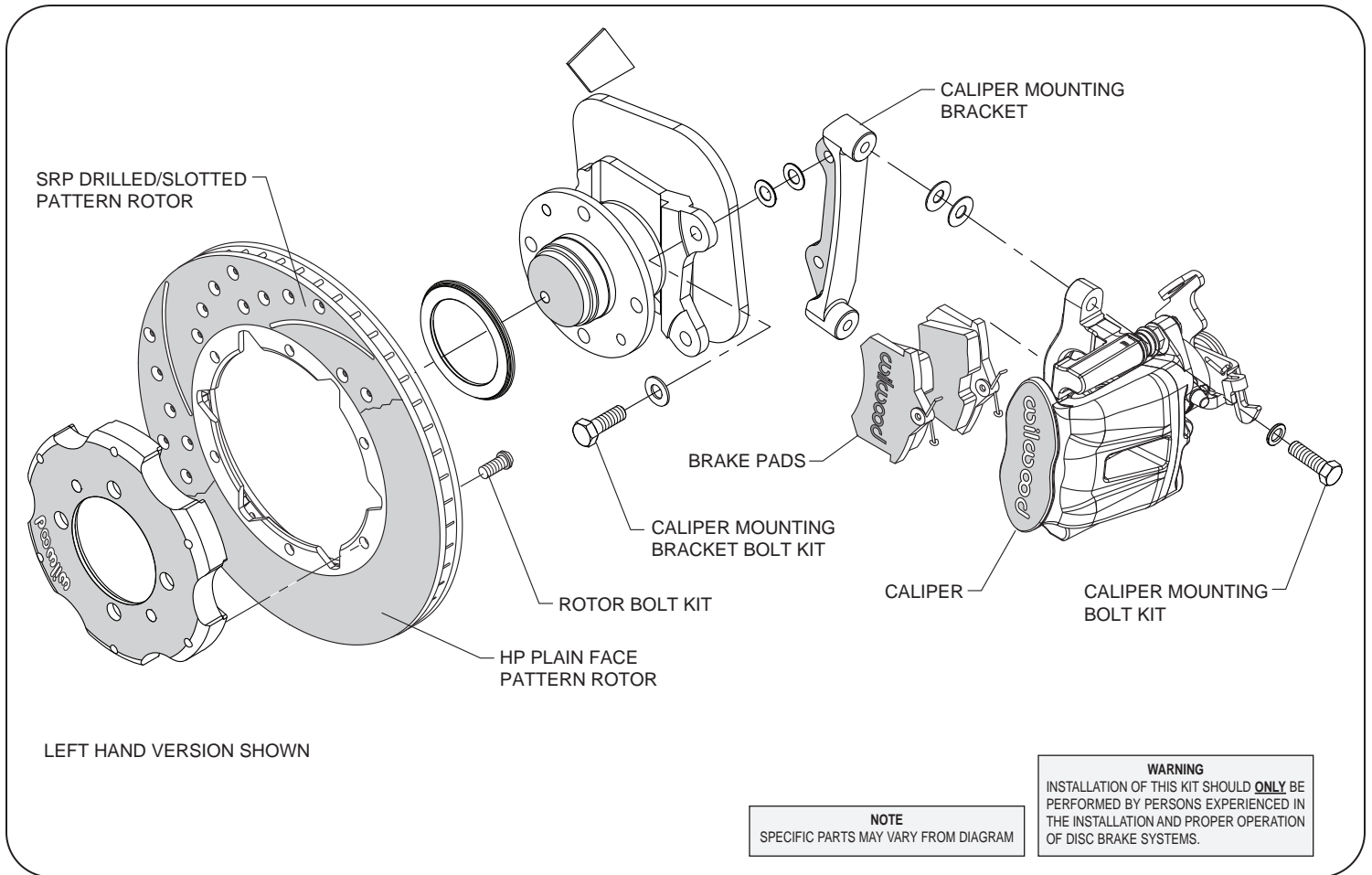

Typical Installation Diagram, Major Components Identified.

ORDERING INFORMATION:

PART NUMBER

DESCRIPTION

140-12768	Rear Parking Brake Kit, Fiat 500, CPB Caliper, 11.00" HP Rotor
140-12768-D	Rear Parking Brake Kit, Fiat 500, CPB Caliper, 11.00" SRP Drilled and Slotted Rotor
140-12768-DR	Rear Parking Brake Kit, Fiat 500, CPB Caliper, 11.00" SRP Drilled & Slotted Rotor, Red Caliper
140-12768-R	Rear Parking Brake Kit, Fiat 500, CPB Caliper, 11.00" HP Rotor, Red Caliper



Need additional information - fast? Utilizing your Smartphone, scan the image at the left to jump to our web site. This code takes you to our home page and social media sites where information is just a click away, [or click here.](#)